

Truck Washer

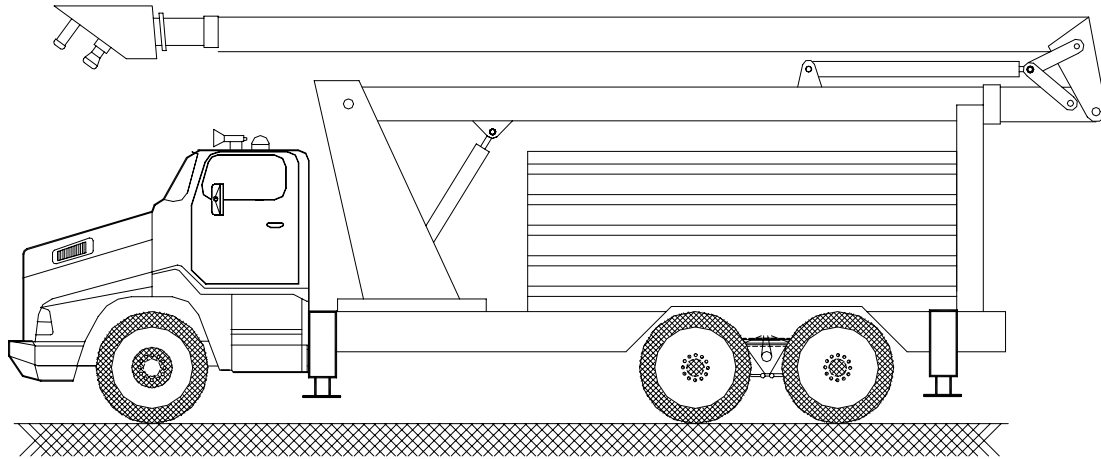

The electric cable washer truck is equipped with articulated booms to reach the high-tension electric cables. The cables are usually in unpaved roads. The truck is filled with water, stands in a suitable location for washing, then the ground system is placed either by connecting it to the base of the tower or in the ground, and spraying it with water. The hydraulic tower is then extended with a proper angle and height to the cable. The operator watches this on the monitor and starts the cleaning process by pointing the water monitor and pushing water bursts, then watching it again on the monitor to make sure it's clean. This unit is mounted on strong trucks such as Volvo, Navistar, and MAN.

Standard Features:

- Power up to 400 HP water-cooled.
- Chassis payload up to 20 tons.
- Chassis 6X4 or 4X4
- Articulated boom 21 m height
- Water tank up to 10 m³
- 360° horizontal rotation both sides
- Hydraulic stability outriggers
- A water level indicator with an over flow outlet.*
- Infra red TV camera to pinpoint the problem areas (option)
- Diesel powered water pump (option)
- A level indicator with an over flow outlet.*
- Sound and light alarm and a siren.
- High-pressure piston pump that work directly on the vehicle's engine.
- 2 hose reels 45 m.
- Water monitor with discontinuous discharge
- Cabinets with aluminum sliding doors on the vehicle sides.
- Hydraulic and water control panel
- Complete control of the vehicle from inside the cabin
- Lighting around the vehicle, the pump and the control panel.
- TV camera on top of the boom (option)
- Ground system

- **The Pump:**

high-pressure plunger pump. Discharge rate up to 12 gallons/min, pressure up to 5000 PSI, powered by the vehicle's engine, and operated from inside the cabin, the pump is equipped with a sieve on the intake of the pump.

- **Articulated boom:**

manufactured from steel of rectangular cross sections, that can withstand large forces. It is installed on the chassis in such a way to give the driver clear vision while driving. The boom is lifted using dual action cylinders, which are equipped with counter balance safety valves. These safety valves prevent the boom from falling in case there is a failure in the hydraulic circuit.

- **TV Camera:**

installed at the end of the boom, equipped with zoom capability, to inspect the wire from all directions for dirt or problems, the scenes can be recorded on tape.

- **Water tank:**

made out of galvanized steel or stainless steel up to 10 m³ with Water wave inhibitors to break the inertia forces on applying the brakes or severe turning. Internal and external reinforcement webs. The top of the tank can be completely removed for cleaning and annual maintenance works. A 50 cm manhole for filling and regular inspection. Inlet for filling the tank from the pump, overflow outlet, ventilation outlet, lower outlet for feeding the pump from the tank, drainage outlet, level indicator for the water level inside the tank, sieve on the inlet line to the pump to prevent dirt from reaching the pump. Manufactured according to international standards. The outer surface of the tank is treated with anti corrosion paints.

- **Reels:**

2 hoses of diameter 1". Length of the hose is 45 meters (or upon demand), located on the sides of the truck. The hoses can withstand high pressure.

- **Cabinets:**

for storage of spare parts and tools.

- **Water monitor:**

is installed at the end of the boom, and controlled from inside the cabin.

- **Control panel:**

equipped with all the suction and drainage pressure gauges, working hour meter, engine speed regulator, as well as the required readings for operation of the water monitor.

- **Sound and light alarm:**

light on the sides of the vehicle, and on the boom.

- **Hydraulic system:**

the hydraulic circuit works using a hydraulic pump powered by the vehicle's engine. 10 micron hydraulic filter, pressure gauge, oil sieve, oil level indicator and heat indicator placed on one of the sides of the hydraulic tank.

- **Modifications and upgrades:**

these are done according to the circumstances and the customer requirements according to the international standard specifications.

ELECTROLAB

Web Site: www.electrolabtrucks.com

Dallah building, 7 A Cornaish ELnil, Maadi, Cairo , Egypt

Tell ++(20)2 25285213/14/15/16

Fax ++25285212

zip code : 11431

Email: electrolab@electrolabtrucks.com

Live Line Insulator Truck washer

IWM-32E

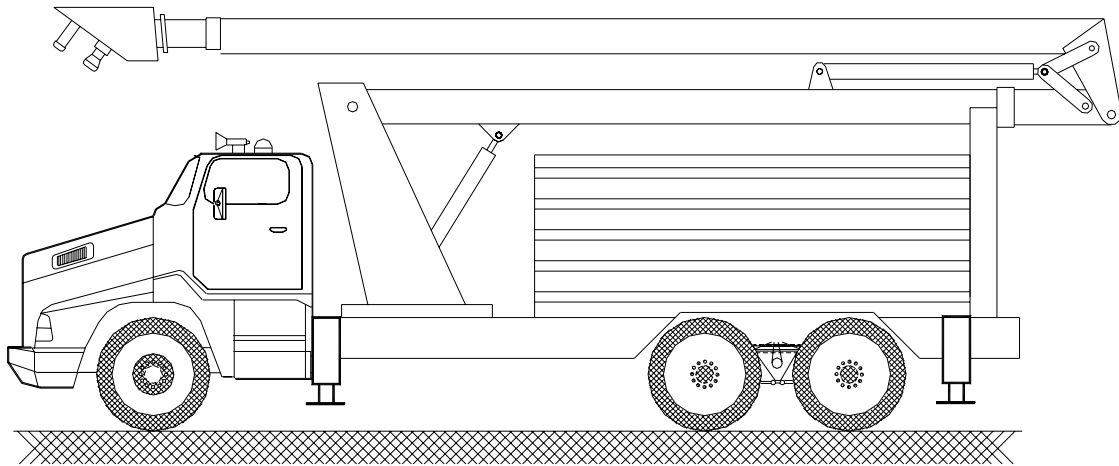

The electric cable washer truck is equipped with articulated booms to reach the high-tension electric cables. The cables are usually in unpaved roads. The truck is filled with water, stands in a suitable location for washing, then the ground system is placed either by connecting it to the base of the tower or in the ground, and spraying it with water. The hydraulic tower is then extended with a proper angle and height to the cable. The operator watches this on the monitor and starts the cleaning process by pointing the water monitor and pushing water bursts, then watching it again on the monitor to make sure it's clean. This unit is mounted on strong trucks such as Volvo, Navistar, and MAN.

Standard Features:

- Power up to 400 HP water-cooled.
- Chassis payload up to 20 tons.
- Chassis 6X4 or 4X4
- Articulated boom 30 m height
- Water tank up to 10 m³
- 360° horizontal rotation both sides
- Hydraulic stability outriggers
- A water level indicator with an over flow outlet.
- Infra red TV camera to pinpoint the problem areas (option)
- Diesel powered water pump (option)
- A level indicator with an over flow outlet.
- Sound and light alarm and a siren.
- High-pressure piston pump that work directly on the vehicle's engine.
- 2 hose reels 45 m.
- Water monitor with discontinuous discharge
- Cabinets with aluminum sliding doors on the vehicle sides.
- Hydraulic and water control panel
- Complete control of the vehicle from inside the cabin
- Lighting around the vehicle, the pump and the control panel.
- TV camera on top of the boom (option)
- Ground system

- **The Pump:**

high-pressure plunger pump. Discharge rate up to 12 gallons/min, pressure up to 5000 PSI, powered by the vehicle's engine, and operated from inside the cabin, the pump is equipped with a sieve on the intake of the pump.

- **Articulated boom:**

manufactured from steel of rectangular cross sections, that can withstand large forces. It is installed on the chassis in such a way to give the driver clear vision while driving. The boom is lifted using dual action cylinders, which are equipped with counter balance safety valves. These safety valves prevent the boom from falling in case there is a failure in the hydraulic circuit.

- **TV Camera:**

installed at the end of the boom, equipped with zoom capability, to inspect the wire from all directions for dirt or problems, the scenes can be recorded on tape.

- **Water tank:**

made out of galvanized steel or stainless steel up to 10 m³ with Water wave inhibitors to break the inertia forces on applying the brakes or severe turning. Internal and external reinforcement webs. The top of the tank can be completely removed for cleaning and annual maintenance works. A 50 cm manhole for filling and regular inspection. Inlet for filling the tank from the pump, overflow outlet, ventilation outlet, lower outlet for feeding the pump from the tank, drainage outlet, level indicator for the water level inside the tank, sieve on the inlet line to the pump to prevent dirt from reaching the pump. Manufactured according to international standards. The outer surface of the tank is treated with anti corrosion paints.

- **Reels:**

2 hoses of diameter 1". Length of the hose is 45 meters (or upon demand), located on the sides of the pump. The hoses can withstand high pressure.

- **Cabinets:**

for storage of spare parts and tools.

- **Water monitor:**

is installed at the end of the boom, and controlled from inside the cabin.

- **Control panel:**

equipped with all the suction and drainage pressure gauges, working hour meter, engine speed regulator, as well as the required readings for operation of the water monitor.

- **Sound and light alarm:**

light on the sides of the vehicle, and on the boom.

- **Hydraulic system:**

the hydraulic circuit works using a hydraulic pump powered by the vehicle's engine. 10 micron hydraulic filter, pressure gauge, oil sieve, oil level indicator and heat indicator placed on one of the sides of the hydraulic tank.

- **Modifications and upgrades:**

these are done according to the circumstances and the customer requirements according to the international standard specifications.